

Part Number: PT938- 35240 (Black)
PT938- 35242 (Silver)

Kit Contents

Item #	Quantity Reqd.	Description
1	1	D-Cab Crushed Tube Board LH
2	1	D-Cab Crushed Tube Board RH

Hardware Bag Contents

Item #	Quantity Reqd.	Description

Additional Items Required for Installation

Item #	Quantity Reqd.	Description

Conflicts

None

Recommended Tools

Personal & Vehicle Protection	Notes
Safety Glasses	
Cut Resistant Gloves	
Special Tools	Notes
Installation Tools	Notes
Torque Wrench	3/8 Drive, 10-50 Nm Range
Driver/Ratchet	12 mm Socket
	6" Extension
Special Chemicals	Notes

General Applicability

MY24 and newer Tacoma, HV models

Recommended Sequence of Application

Item #	Accessory

*Mandatory

Vehicle Service Parts (may be required for reassembly)

Item #	Quantity Reqd.	Description
1	16	90119-A0582 - Bolt

Legend

 **STOP:** Damage to the vehicle may occur. Do not proceed until process has been complied with.

 **OPERATOR SAFETY:** Use caution to avoid risk of injury.

 **CAUTION:** A process that must be carefully observed in order to reduce the risk of damage to the accessory/vehicle and to ensure a quality installation.

 **TOOLS & EQUIPMENT:** Used in Figures calls out the specific tools and equipment recommended for this process.

 **REVISION MARK:** This mark highlights a change in installation with respect to previous issue.

 **SAFETY TORQUE:** This mark indicates that torque is related to safety.

 **REGULATORY MARK:** This mark indicates the component is related to regulatory compliance

Care must be taken when installing this accessory to ensure damage does not occur to the vehicle. The installation of this accessory should follow approved guidelines to ensure a quality installation.

These guidelines can be found in the "Accessory Installation Practices" document.

This document covers such items as:

- Vehicle Protection (use of covers and blankets, cleaning chemicals, etc.).
- Safety (eye protection, rechecking torque procedure, etc.).
- Vehicle Disassembly/Reassembly (panel removal, part storage, etc.).
- Electrical Component Disassembly/Reassembly (battery disconnection, connector removal, etc.).

Please see your Toyota dealer for a copy of this document.

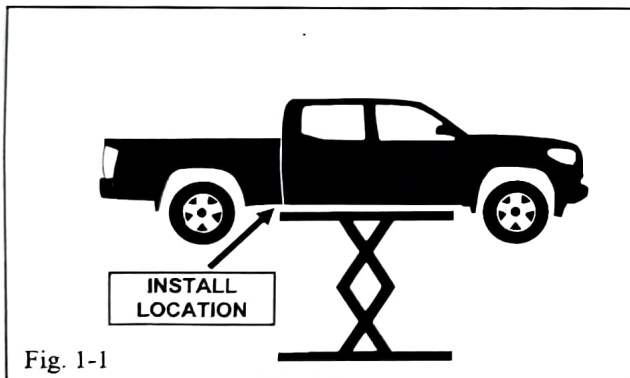
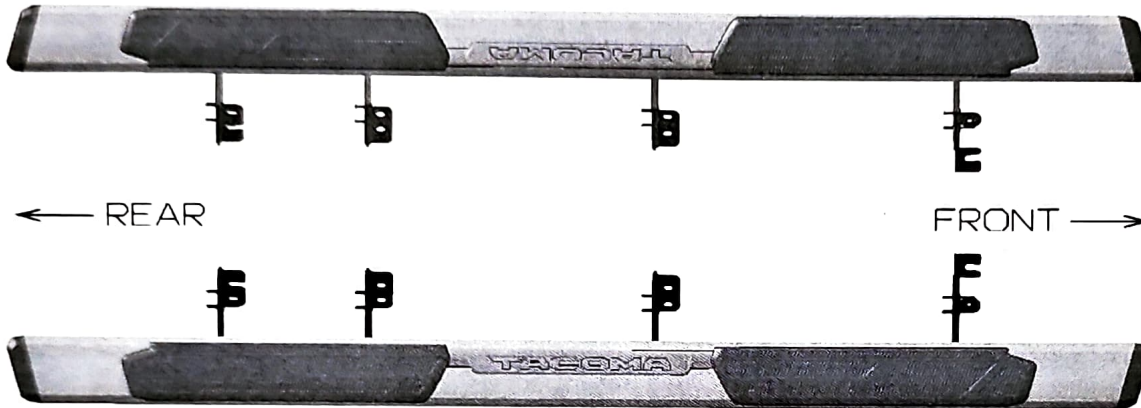

Fig. 1-1

1. Prepare the vehicle.

- STOP** (a) Ensure vehicle is clean prior to the running board installation.
- (b) Lift the vehicle, making sure to leave room for installation of the Crushed Tube Board (Fig. 1-1).

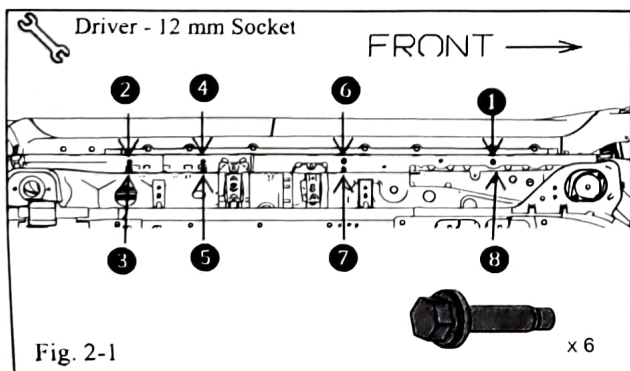
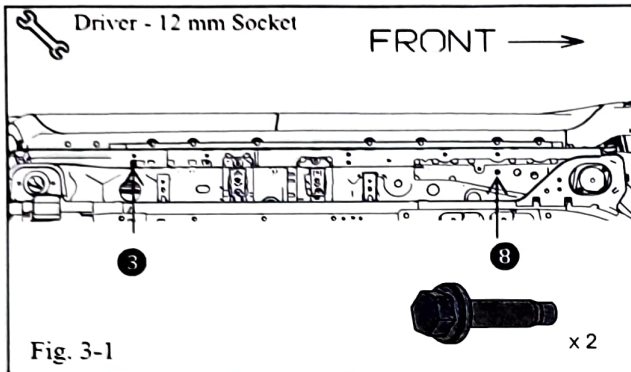

Fig. 2-1

2. Remove Mounting Bolts

- (a) Using a 12mm socket remove M8 bolts (90119-A0582) all locations except **3** and **8** (Fig. 2-1).

! NOTE: Retain the bolts for re-installation.



3. Loosen Mounting Bolts at temp set locations

- (a) Loosen the M8 bolts at locations **3** and **8**, (Fig 3-1), making sure to leave 6-8 mm of clearance between the rocker surface and the bolt washer .

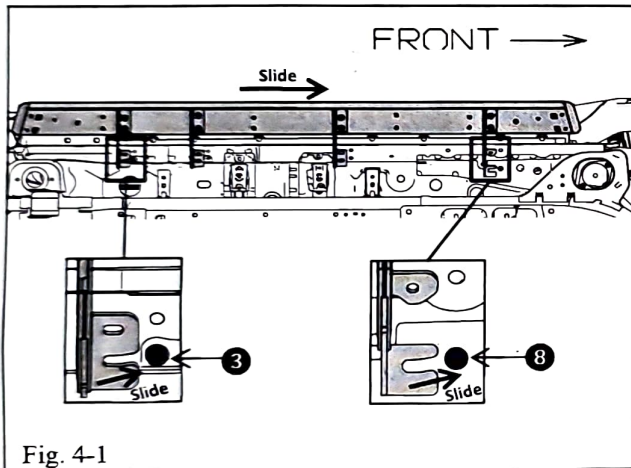

4. Install the Crushed Tube Board

- ⚠** (a) Install the board onto the bolts installed in the previous step by sliding the board's temp set slots (open slots on brackets) forward and slightly outboard (Fig 4-1). Ensure that the bolts are fully inserted into the open slots. Take care not to bump the board in this condition as it might fall out of the temp set slots.
- +** (b) Insert and hand start bolt in position **1** then position **2** (Fig. 4-2)
- (c) Insert and hand start remaining (4) M8 bolts in the prescribed order from **3** to **7** (Fig. 4-2)
- (d) Torque all the bolts in the prescribed order from **1** through **8** (Fig. 4-2).
- ⚠** (e) Re-Torque all the bolts in the same sequence.
Torque: 34 +/- 6 Nm [25.1 ft-lbs.]

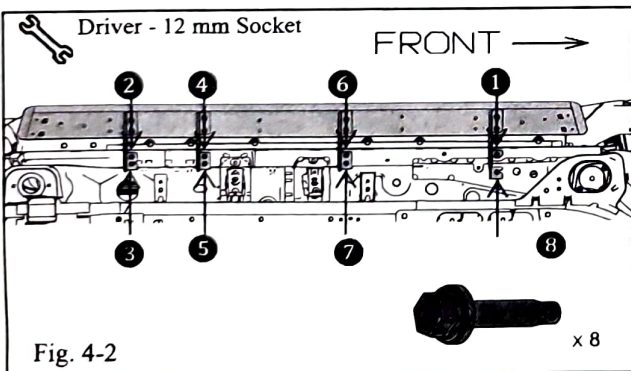

TOYOTA TACOMA, HV 2024- D-CAB CRUSHED TUBE BOARD

Checklist - these points **MUST** be checked to ensure a quality installation.

<u>Check:</u>	<u>Look For:</u>
<u>Accessory Function Checks</u> <input type="checkbox"/> <input type="checkbox"/> <input type="checkbox"/> <input type="checkbox"/>	Removed items have been discarded & replaced items are in place
<u>Vehicle Function Checks</u> <input type="checkbox"/> <input type="checkbox"/> <input type="checkbox"/>	
<u>Vehicle Appearance Check</u> <input type="checkbox"/> After accessory installation and removal of protective cover(s), perform a visual inspection.	Ensure no damage (including scuffs and scratches) was caused during the installation process. (For PPO installations, refer to TMNA Accessory Quality Shipping Standard.)